

Inorganic Chemistry

Craig Barnes
552 Buehler Hall

cebarnes@utk.edu
Phone (865)974-3141

- 1977 B.S. degree from Harvey Mudd College, Claremont, CA
- 1982 Ph.D. from Stanford University
Thesis: Metalloporphyrin Dimers with Multiple Metal- Metal Bonds
- 1983 NATO Postdoctoral fellow with Professor Wolfgang Herrmann, Frankfurt, Germany
- 1984 Alexander Von Humbolt Fellow with Professor Herrmann, Frankfurt, Germany
- 1985 University of Tennessee

Description of Research Program

My research program is broadly focused on the properties and reactions of inorganic complexes and the directed synthesis of new nanostructured materials and catalysts.

Nanostructured Building Block Solids

We are currently developing the chemistry of the silicate cube, Si_8O_{20} . As shown in accompanying illustration, this building block consists of a cube with silicon at the corners and bridging oxygens along each of the 12 edges. Eight additional terminal oxygen atoms extend out from the body of the cube, one from each Si atom.

The Si_8O_{20} group is one of the most easily synthesized soluble silicates known. We have recently developed several new methods of attaching functional groups to this cube and have

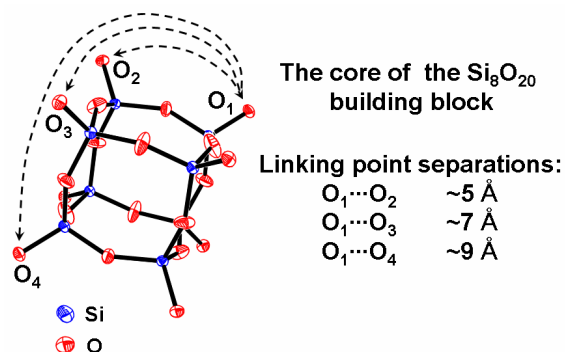

Building block catalysts based on the Si_8O_{20} cube

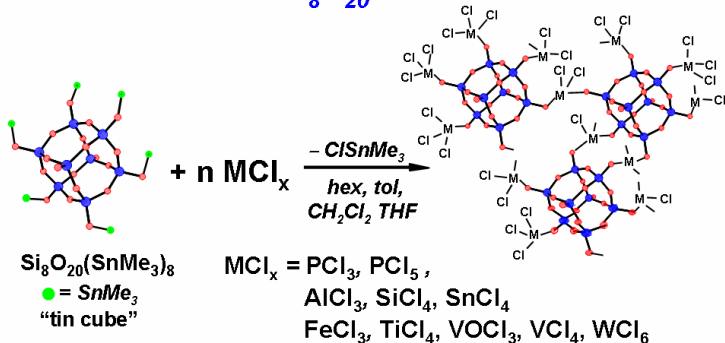

Nanostructured building block matrices as heterogeneous oxidation catalysts

An extension of the building block concept involves linking different types of building blocks together to make completely new catalysts. As shown here, there are many polynuclear metal oxo complexes such as the Ti_2 -alkoxide that can be linked together with the "tin cube". Between these two approaches to building block syntheses, we believe that we can prepare single site, monodispersed functional groups on silica supports with virtually any nuclearity desired. This would be a fundamental advancement in the area of heterogeneous catalysis.

begun to explore its inorganic and organometallic chemistry from a number of perspectives. The Si_8O_{20} cube can be thought of as a new molecular platform from which to prepare dendritic or "starburst" polymers. We are currently investigating the incorporation of cube into novel metal oxide matrices such as $\text{Si}_8\text{O}_{20}[\text{MCl}_n]_x$ where $\text{M} = \text{Si}, \text{Al}, \text{Ti}, \text{V}, \text{Cr}, \text{W}, \text{Sn}$. The catalytic properties of these are many other possible combinations of this cube with metal oxides are currently under investigation.

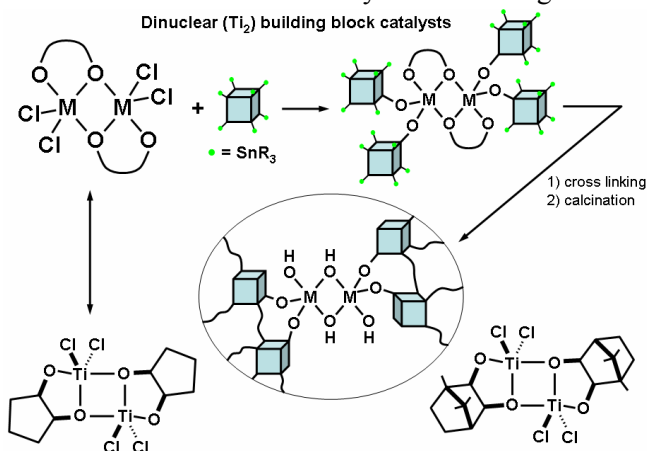

Members of my group are exposed to a wide variety of synthetic and spectroscopic techniques. Synthetic techniques include the preparation and handling of the air sensitive organic and organometallic complexes and materials on vacuum lines and inert atmosphere boxes. All manner of spectroscopic techniques are utilized in the characterization of the complexes and materials we prepare. Surface area and EXAFS (Extended X-ray Absorption Fine structure) spectroscopic are used for sol-gel and solid state materials. NMR spectroscopy is of fundamental importance in the research performed by the members of my group – from solid state to solution, multinuclear, multidimensional, variable temperature. X-Ray crystallography is also frequently called upon as a final determination of the structure for discrete complexes or crystalline materials.

Finally, after synthesis and characterization we also test our catalysts in a variety of reactions including solid acid catalysis, selective oxidation reactions and olefin polymerizations. We have constructed a gas phase flow micro reactor for some of our selective oxidation work. A schematic illustration of the reactor is shown here.

The projects described above are intended to give students some insight into both ongoing research as well as our general fields of interests. In addition to technical and theoretical training, students learn how to frame scientific arguments and strategies in designing and conducting research as well as present their results in public scientific forums. Students interested in research in my group are encouraged to consult with myself and my research students.

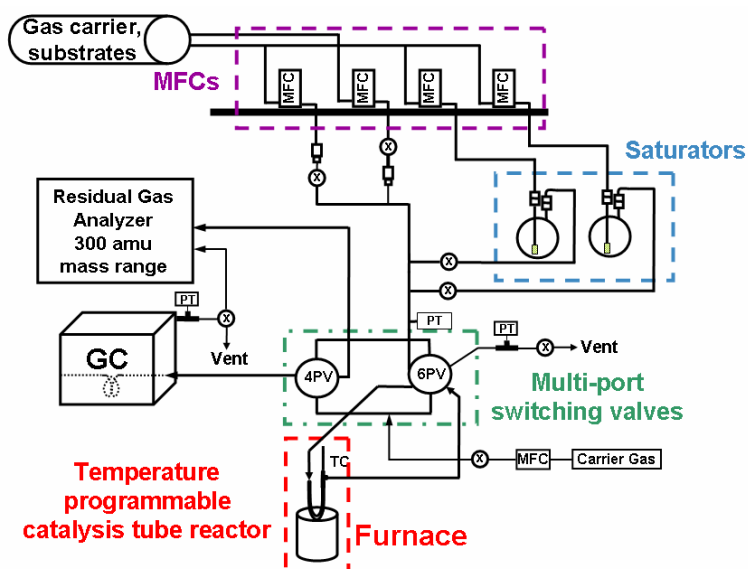

Selected References

1. Clark, J. C.; Barnes, C. E., "Reaction of the Si_8O_{20} (SnMe_3) $_8$ Building Block with Silyl Chlorides: A New Synthetic Methodology for Preparing Nanostructured Building Block Solids", *Chem. Mater.*, **2007**, *19*, 3212-18.
2. Clark, J. C.; Saengkerdsub, S.; Eldridge, G. T.; Campagna, C.; Barnes, C. E., "Synthesis and structure of functional spherosilicate building block molecules for materials synthesis", *J. Organomet. Chem.*, **2006**, *691*, 3213-22.
3. Ghosh, N. N.; Clark, J. C.; Eldridge, G. T.; Barnes, C. E., "Building block syntheses of site-isolated vanadyl groups in silicate oxides", *Chemical Communications*, **2004**, 856-57.
4. Dai, S.; Barnes, C. E., Mesoporous Materials. In *Encyclopedia of Supramolecular Chemistry*, Atwood, J.; Steed, J., Eds. Elsevier: New York, 2003.
5. C.E. Barnes, Y. Shin, S. Saengkerdsub and S. Dai. "EXAFS Study of Uranyl Nitrate Dimer at High and Low Temperature", *Inorganic Chemistry*, **2000**, *39*, 862.
6. Y.H. Ju, O.F. Webb, S. Lin and C.E. Barnes. "Synthesis and Characterization of ordered Mesoporous Anion – Exchange Inorganic /Organic Hybrid Resins for Radionuclide Separation", *Ing. Eng. Chem. Res.*, **2000** *39*, 550.
7. Barnes, C. E.; Shin, Y.; Saengkerdsub, S.; Dai, S., "EXAFS Study of Uranyl Nitrate Dimer at High and Low Temperature", *Inorganic Chemistry*, **2000**, *39*, 862-64.

Funding:

Basic Energy Sciences of the Department of Energy (BES/DOE)
Petroleum Research Fund